

Creating an EN17206 compliant system for fixed-speed hoists

Introduction

Deploying a DigiHoist controller and Libra load cells to create an EN17206 compliant system for fixed speed hoists.

As demand increases for EN17206 compliant systems around the world, many fixed-speed systems would not meet the requirements of this standard. However, a budget-sensitive and compliant rigging option can be achieved by deploying a combination of a Kinesys Digihoist controller, encoders, and Libra load cells where load and position data can be used to stop motion prior to overload.

For rigging applications using variable speed hoists, [Apex](#) offers a straightforward and EN17206-compliant system.

HARA (Hazard Analysis & Risk Assessment)

It has always been the case that a HARA will determine the suitability of equipment for an application. EN17206 provides additional guidance on the required safety functions for a given application.



Applicable EN17206 “Use Cases” for DigiHoist systems

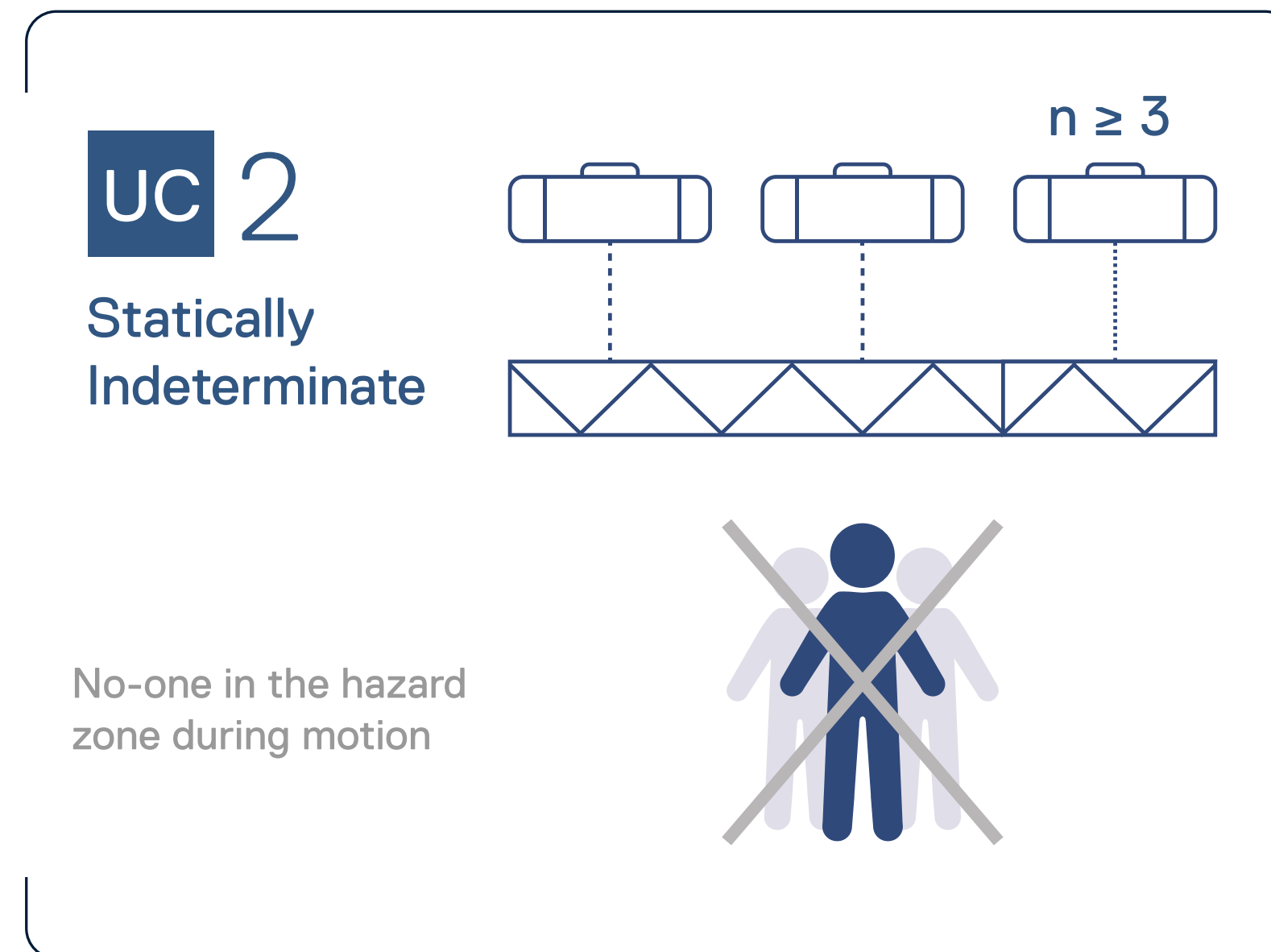
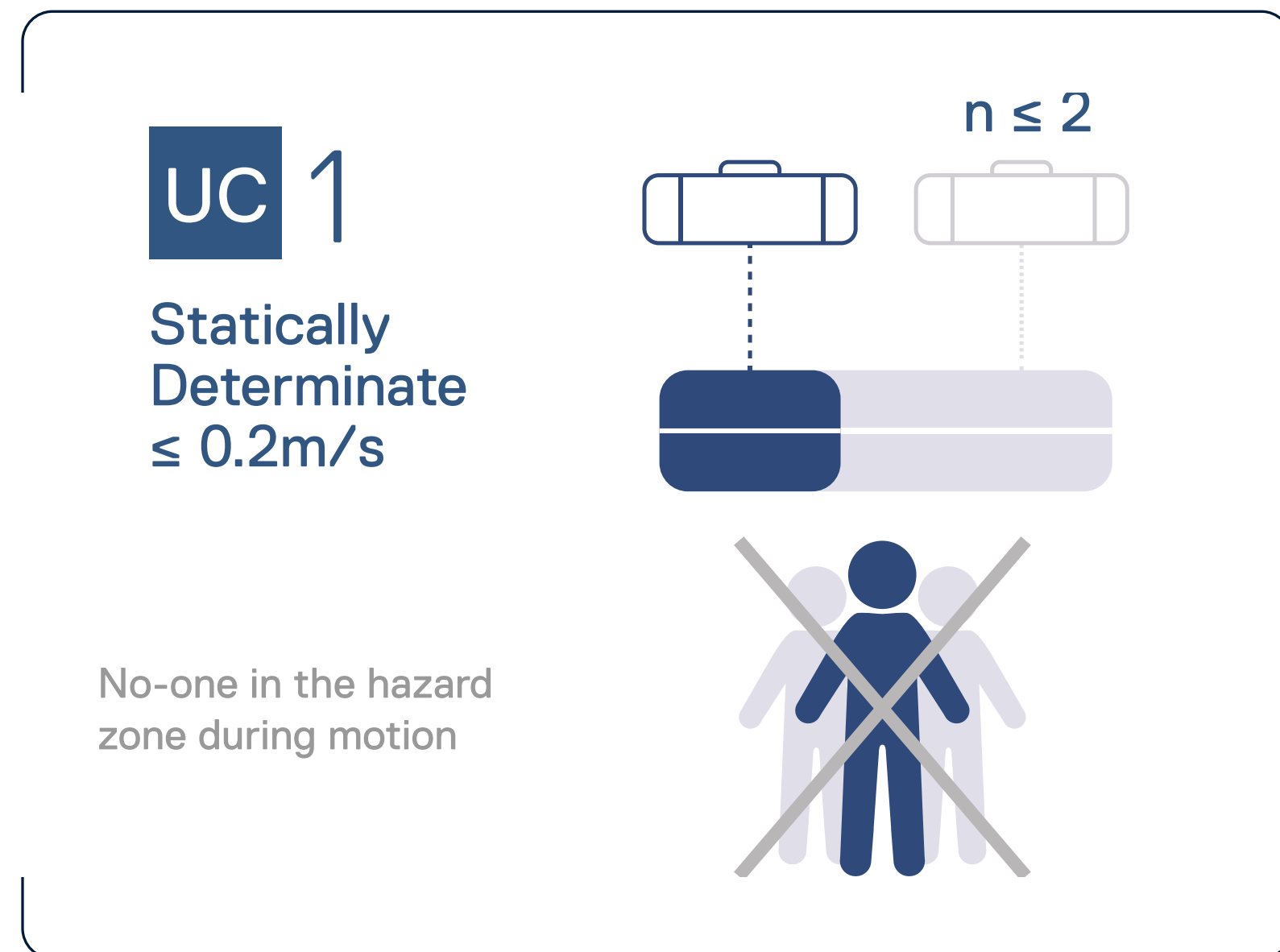

Note

Position encoders are recommended for applications with multiple hoists, where synchronized lifting is required (see page 6)

SD – Statically determinate load system

In statically determinate load systems all loads and reactions (applied loads of the individual axes and therefore of the suspension points) are known.

Examples of statically determinate load systems include:

- a) loads on individual axes (point load);
- b) distributed loads on two axes.

SI – Statically indeterminate load systems

In statically indeterminate load systems the reactions (applied loads of the individual axes and therefore of the suspension points) cannot be fully determined without measurement using dynamometers or loads cells.

Not applicable EN17206 “Use Cases” for DigiHoist systems

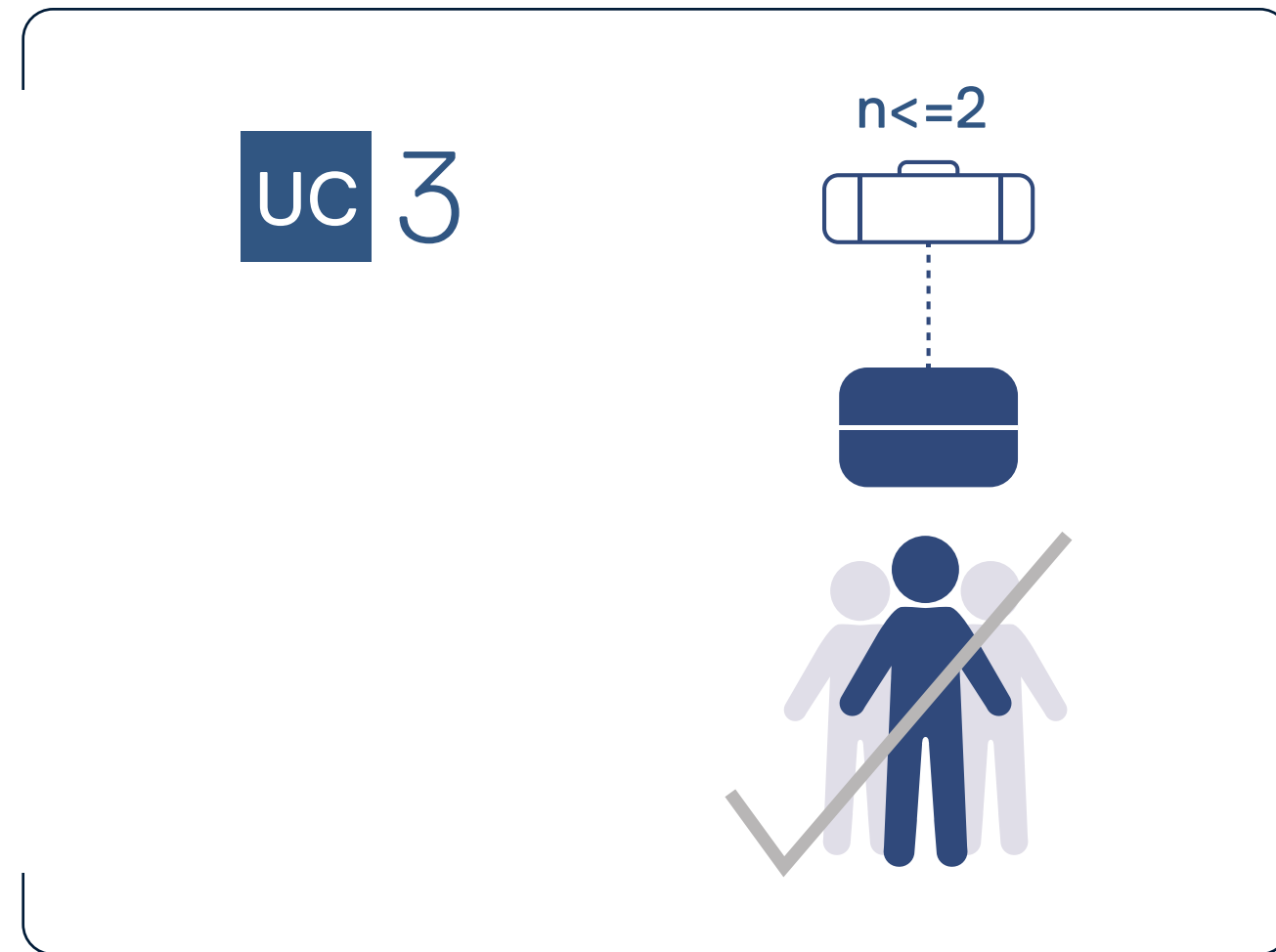

✗ Why not?

- No protection against position deviation
- No protection against speed deviation
- No protection against over speed
- No protection against brake failure

The variability of speed* means precise synchronization is difficult to achieve, so fixed speed hoists are not suitable for show moves in many cases, but may be acceptable for some applications, e.g. flying a gauze.

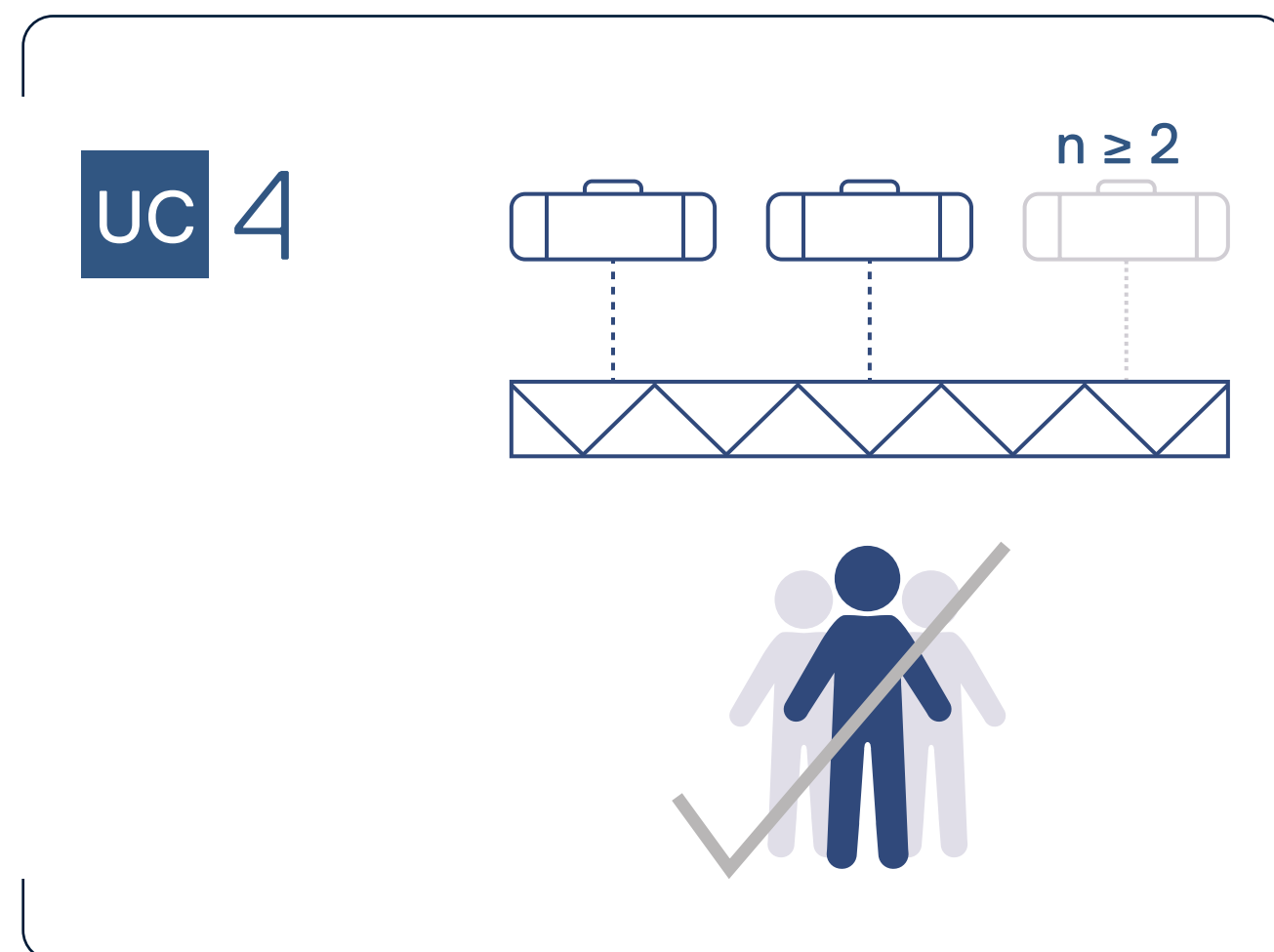

* Fixed speed hoists will generally run at speeds within 2% of each other, but at worst case can run at 5% different speeds

EN17206 compliant fixed speed system: overview of



Note: for multiple hoists the HARA may determine that position encoders are required, in which case the upgrade module must be fitted (see next page).

Up to 8 Libra load cells may be connected in a daisy-chain to the Digihoist, or a Libra Hub may be used to make cabling easier.

Note: limit switches must be fully commissioned.

Special considerations for multiple hoists (UC2)

- Position encoders are recommended for applications with multiple hoists, where synchronized lifting is required.
- The Digihoist controller(s) will require the Ethernet and Positioning upgrade.
- When lifting complex loads with multiple hoists it may be necessary to break the lift down into smaller sections to avoid overloading individual hoists. e.g. instead of lifting from 0m to 10m, lift to 2m, then level off, lift to 4m and level off etc.

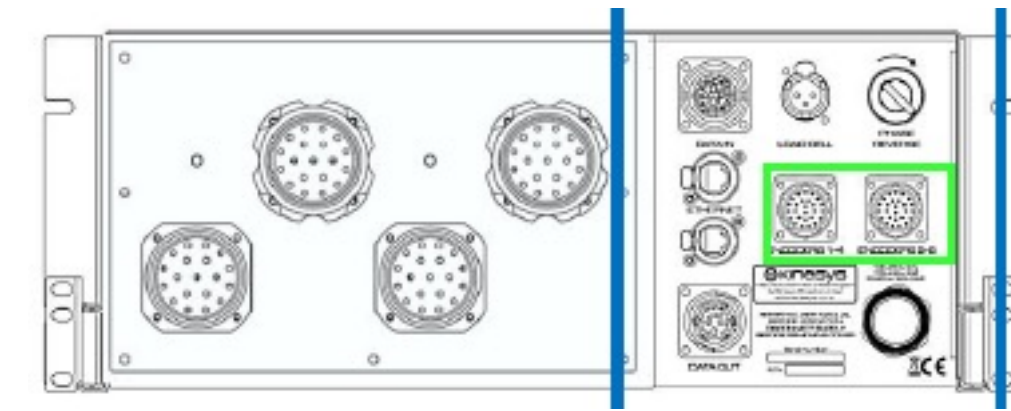

Digihoist rear panel showing encoder connectors
(Available with optional upgrade only).

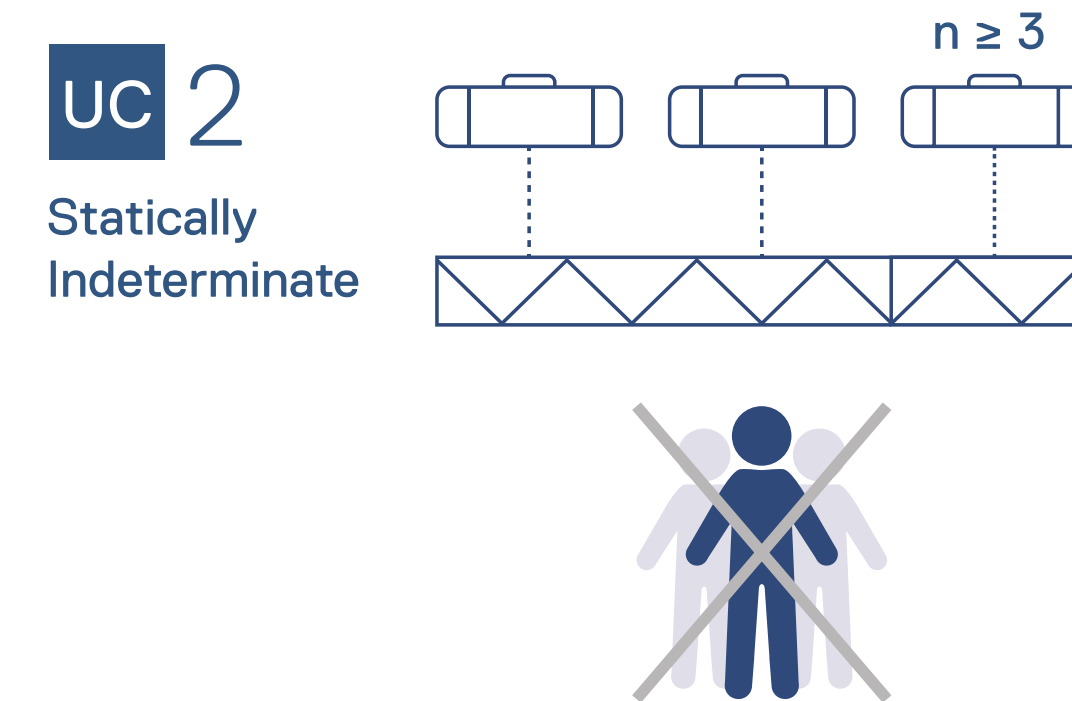

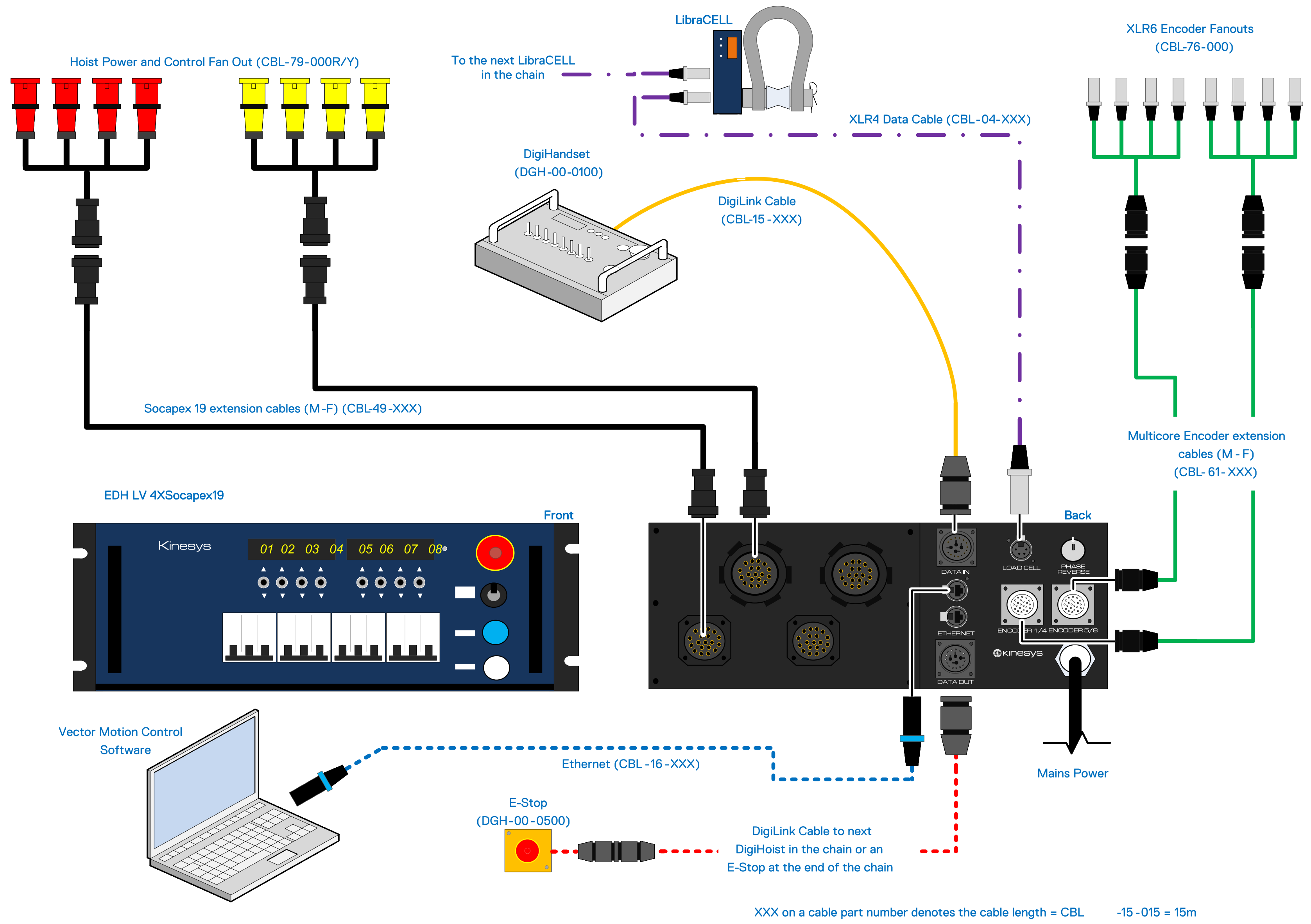

XXX on a cable part number denotes the cable length = CBL -15 -015 = 15m

Summary

Kinesys Digihoist and Libra provide a cost-effective option for fixed-speed chain hoist systems to enable EN17206 compliance.

Looking for more information on this topic, or guidance on what this means for you and your projects?

Please get in touch with our support or technical-sales team.

sales@kinesys.com

Contact Kinesys

Telephone

UK +44 (0) 20 8481 9850

USA +1 (844) KINESYS

Sales

sales@kinesys.com

Support

support@kinesys.com

Web

www.kinesys.com

Facebook: [Kinesys](#)

Twitter: [@kinesysprojects](#)

LinkedIn: [Kinesys](#)

Instagram: [@kinesysprojects](#)

Designed in the UK

The information in this document is provided as general information only and no representation or warranty is expressly or impliedly given to the suitability of this product for any particular project, purpose or location.

All data, features, images and product specifications may vary and are subject to change without notice

DIHG-2023-02

© 2023 Kinesys Projects Ltd.